

Apr 2026

Issue 20

The Milton Abbas Bulletin



Welcome!

Hello Readers and welcome to our April edition of the bulletin!

It's difficult to believe that we are already entering the fourth month of the year, and it is so lovely to see nature doing what she does best and showing all the wonderful signs of spring and the warmer months ahead.

Did any of you fall for an April fool? April 1st is celebrated all over the world as a morning of jokes and tricks. I hope you all remembered to not play a trick after noon otherwise you are the fool!

1st to 9th April is Passover, or Pesach and is one of the most important festivals in the Jewish calendar, commemorating the anniversary of the Exodus from Egyptian slavery. 2nd April is World Autism Awareness Day.

Good Friday falls on 3rd April; this Christian celebration commemorates the crucifixion of Jesus and his death at Calvary. Hot Cross Buns are traditionally eaten today. Easter Day is Sunday 5th and is the Christian celebration of Christ's resurrection. It has been adopted across the world as a secular spring festival, celebrated by exchanging chocolate eggs and eating family meals and focusing on symbols such as eggs, rabbits and chicks. Easter Monday is a Bank Holiday in the UK.

9th April is Unicorn Day, and a day to celebrate the most popular mythical creature ever, which is also the symbol of Scotland.

10th April is Siblings Day, based on traditional Indian festival of Rakshabandhan, which is hundreds of years old, honouring the relationships of siblings.

11th April is National Pet Day, created to celebrate the joy pets bring to our lives and to bring awareness to animals awaiting a forever home in shelters.

12th April is Space Day, the International Day of Human Space Flight celebrating the anniversary of the first human space flight by Yuri Gagarin in 1961. www.youtube.com/watch?v=CWdp5_0vual

National Scrabble Day is 13th April, the highest single word score being 347 points during a 2017 championship match.

17th April is Bat Appreciation Day! Bats are the only mammal which can fly. We must appreciate these amazing creatures and the role that bats play in the Earth's ecosystem.

18th April is World Heritage Day an international Day for Monuments and Sites, promoting awareness about the diversity of the cultural heritage of humanity. Plus it is World Circus Day, celebrating Circus Arts and Culture.

Earth Day falls on 22nd April and is a worldwide event to raise awareness of the environmental issues which face the whole of planet Earth.

23rd April is St Georges Day, a celebration of England's patron saint, celebrated by flying the English flag and by taking part in traditional activities such as Morris dancing. It was also both Shakespeare's birthday and the date of his death and celebrations are held in his home town of Stratford-upon-Avon and around the UK for National Shakespeare Day. This day is also World Book Night, inspiring people to read more. Each year books are donated to organisations across the UK so that they can reach people who don't regularly read for pleasure nor have access to books.

Penguin Day is 25th April bringing awareness to the dangers that penguin's habitats face, as well as the number of penguin species which are endangered.

International Dance Day is 29th April and International Jazz Day falls on 30th April.

April's birth flowers, the daisy and sweet pea, bring joy to April-born individuals. Daisies symbolise innocence and purity and have a rich history dating back to ancient Egypt. Sweet peas, with their sweet fragrance, represent delicate pleasure, friendship, and gratitude.

April's birthstone is the diamond. It is thought to provide the person wearing it with better relationships and an increase in inner strength.

Have a good Easter everyone, enjoy having a village pub once again and stay safe!

Best regards
Mrs Ed x

Plant and Veg Swap

Our Plant & Veg swap is back for 2026! If you have any spare seedlings, plants, or vegetables, please drop them off in our surgery foyer and then anyone who comes to the surgery can pick up something on their way out.

Nothing beats the taste of fresh fruit, vegetables and herbs grown in your own garden - or the satisfaction and enjoyment you can get from doing it. Not sure what to grow or where to start? The Royal Horticultural Society have all the tips and advice you need, including a Grow Your Own newsletter featuring handy fruit and vegetable tips, advice on what to do in your garden or allotment. Go to www.rhs.org.uk/advice/grow-your-own for more information.

Did you know that May is National Walking Month?

Walking is an easy and accessible way to improve physical and mental health and even a 20-minute walk can reduce the risk of several preventable health conditions, including certain cancers, depression, heart disease and Type 2 diabetes.

Why not join our Walking Group on a Wednesday at 10am? To see the walking programme for May 2026 please see our surgery website www.masurgery.co.uk/wellbeing-team. If you do not have access to the internet and would like a printout of the programme, please let Kelly or Anna, our Social Prescribers, know and they can arrange for one to be sent to you.

Whatever you end up doing this May, let's keep on moving forward. Do something today that your future self will thank you for!

A Plea for Wee!

Your urine sample is as important as the blood tests that you have taken at your Long Term Condition Reviews. Testing your urine will show us if there is any protein leakage which would be a sign that your kidneys are not working as well as they should. This can happen even if the kidney function test (blood test) is normal.

Please bring a urine sample if you are coming for your annual review for:

- o Diabetes
- o Hypertension
- o Chronic Kidney Disease
- o Heart Failure

Your sample should be from the first wee of the day. Sample kits are available from reception if you can collect one before your appointment - this is the best option - but if not, please bring your sample in a clean screw top container.

Surgery Closures

The surgery will be closed on **Friday 3rd April, Saturday 4th April and Monday 6th April 2026** for the Easter Bank Holiday weekend.

We apologize for any inconvenience caused. For out of hours care or advice during closures, please call 111. In the case of an emergency, call 999.



Opening Hours

Mon 9-4 Tues- CLOSED

Wed 9-4 Thurs 9-4

Fri 9-4 Sat 9-4

Sun 10-3

Easter Opening Hours

Good Friday 9-4

Saturday 9-4

Easter Sunday CLOSED

Easter Monday 9-4

THE HAMBRO ARMS

EASTER
MONDAY
4PM

LIVE



MUSIC

COME AND JOIN US
FOR LIVE MUSIC FROM
THE TALENTED:

THE HAMBRO ARMS
MILTON ABBAS
BLANDFORD FORUM
DT11 0BP

Losados



The Hambro Arms



THE HAMBRO ARMS OPENING HOURS

Friday 27th March	6pm - 11pm
Saturday 28th March	12pm - 11pm
Sunday 29th March	12pm - 10pm
Monday 30th March	Closed
Tuesday 31st March	Closed
Wednesday 1st April	12pm - 3pm 6pm - 10pm
Thursday 2nd April	12pm - 3pm 6pm - 10pm
Good Friday	12pm - 11pm
Easter Saturday	12pm - 11pm
Easter Sunday	12pm - 11pm
Easter Monday	12pm - 10pm
Tuesday 7th April	Closed
Wednesday 8th April	12pm - 3pm 6pm - 10pm
Thursday 9th April	12pm - 3pm 6pm - 10pm
Friday 10th April	12pm - 3pm 6pm - 11pm
Saturday 11th April	12pm - 11pm
Sunday 12th April	12pm - 10pm

www.thehambroarms.co.uk | 01258 721594





Wing Walking for Weldmar !

On 4th May 2026, Lisa Baker and Stuart Driver will be undertaking a Wing-Walk on a vintage Bi-Plane at Compton Abbas Airfield to raise funds for Weldmar Hospice.

Weldmar recently provided palliative care for our beloved friend, Bev Martin, and we were blown away by the fantastic work they undertook for her and her family

Weldmar needs to raise more than £27,000 every day to provide specialist care for adults in Dorset with life limiting illnesses, and support for their loved ones. Just 19% of these costs are met by the NHS, the rest comes from the generosity of the local community.

If you are able, and would like to support this genuinely fantastic cause, then please use the QR code or follow the link below to help Lisa and I meet our target:

www.justgiving.com/page/stuartandlisa?utm_medium=FR&utm_source=CL&utm_campaign=021

Thank you all – it’s been nice knowing you...
Stu & Lisa x

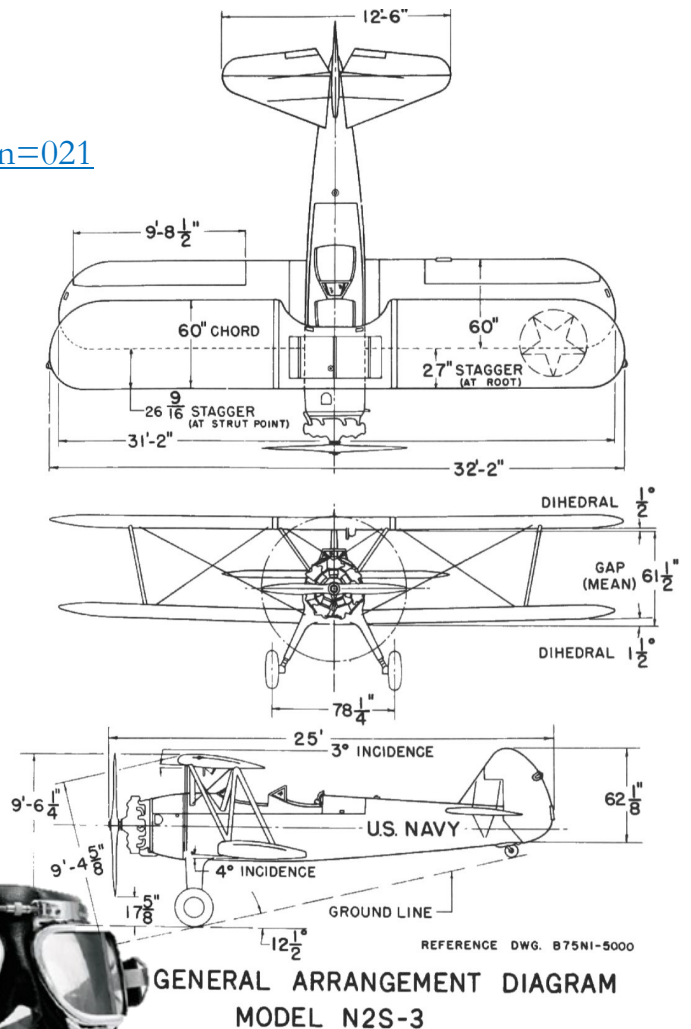

Steeptonbill Farm Shop

Selling beautifully fresh, locally-grown produce all year round!

Opening hours:

Monday to Thursday: Closed

Friday to Sunday: 10:00 - 16:00



Contact Steve at steeptonbill@gmail.com for all your seasonal produce

Steve currently still has Purple Sprouting available, plus lots of Chives:

Chives are nutrient-dense, low-calorie herbs packed with vitamin K, vitamin C, and antioxidants that boost immunity, improve bone health, and support heart health. Their sulphur compounds may help prevent cancer, while choline and folate aid memory. They also reduce inflammation, aid digestion, and provide antibacterial benefits



A classic scrambled eggs recipe here:

www.bbc.co.uk/food/recipes/scrambled_egg_with_15456

Thought for the Month

I wonder if you have a favourite story - one you've heard or read many times. The kind that stays with you, because it says something true about life. Here's a simple one:

There was once a place of desolation - a stagnant canal, broken lamp-posts, boarded-up flats. No grass, no trees, just neglect. Years earlier, an explosion had taken the lives of Mabel and Arthur, and for 30 years nothing grew there.

Until one autumn, a seed took root.

At first, no one noticed. But in time, something impossible to ignore appeared - a tall sunflower, bright and golden, standing in the middle of all that grey. Some people were lifted by its beauty. Others didn't know what to make of it. It felt out of place - almost uncomfortable - because it showed the emptiness around it for what it was.

Eventually, people grew resentful. One evening, a crowd gathered. They trampled the sunflower, crushed it, destroyed it, and walked away. And yet... When they did, the flower was full of seeds. Those seeds were scattered and became buried in the ground.

The following spring, that same place was filled with sunflowers. Where there had been emptiness, there was life. Where there had been loss, there was beauty. At last there were flowers on the grave of Mabel and Arthur.

Christians can be summed up in five simple words:

“Love is stronger than death.”

At Easter, they remember a story that brings those words to life. At the heart of it is Jesus, who held onto love even in the face of suffering and death - exposed and vulnerable before the world, with few standing beside him and many looking on without understanding. And perhaps we need to hear that now more than ever.

So much of what we hear, read and watch can feel focused on death, loss and division. This is not a denial of pain - far from it. But it is a reminder that love has the capacity to be stronger still. But whether or not you think of Easter in religious terms, there is something here for all of us. Because we see it in everyday life too. In acts of kindness. In neighbours looking out for one another. In small gestures that bring light into difficult places. In communities - like our own village - where care, friendship and generosity quietly take root and grow. Again and again, love shows itself to be life-giving.

This Easter, may we notice those small signs of hope around us. And may we each play our part in planting seeds of kindness, care and connection - helping our community to flourish.

Because, in the end,

Love is stronger than death.

Easter Blessings
Rev'd Lewis

Reminder! Our Easter Day Service will take place at 10:30 in St James Church - all are welcome!

Milton Abbas Lunch Club

The April Lunch Club will be on **Weds 8th April at The Reading Rooms**. All villagers over 55 are welcome, and we provide something warming and hearty to fill your tummy!

Main will be Sue Hodder's fabulous Fish Pie, followed by Sticky Toffee Pudding, courtesy of Freddy Robinson

The cost for the meal will be £5 per head, payable to Trevor Payne on the day

To book your place, please email Jennifer by 3rd April:

hrrssnsup@aol.com



SMITHS

DORSET

SMITHS KITCHEN *Easter Sunday*

STARTERS

Dorset Red Croquettes, Chilli Jam Aioli
Chicken Liver Parfait, Crostini
or
Smoked Salmon Mousse Filo Tart

MAINS

Short Rib of Beef
Slow Cooked Pork Belly
Mushroom & Nut Wellington
or
Crab Thermidor
(£5 Supplement)

DESSERTS

Cherry Bakewell Cheesecake
Hot Cross Bun Pudding & Cream
or
Trio of Dorset Cheese, Homemade Crackers,
Pear Compote
(£3 Supplement)

2 Courses £28
3 Courses £35



FIZZ FRIDAY 3rd April

SEAFOOD PLATTERS!



Live music from

Flaming Cactus Band





Come and join us for lots of Easter Fun!

Sunday 29th March at 2:30pm

**Old School Room, Winterborne Whitechurch, DT11 0an
(parking available next to the church)**

Easter crafts, Activities and Games, and an Easter Egg Hunt!

ALL AGES WELCOME! CHILDREN MUST BE ACCOMPANIED BY AN ADULT



Winterborne Valley & Milton Abbas Benefice

Website : www.wvmabenefice.uk

Facebook : Churches in the Winterborne Valley & Milton Abbas Benefice



Milton Abbas Local History Group

Milton Abbas Local History Group is proving that history can be as gripping as any drama. At our March meeting, members were taken on a remarkable journey into the harsh realities of the 17th century in a powerful talk, “Surviving the 17th Century,” by founder Pamela Phillips.

Far from dates and dry facts, this was history at its most human. From the ever-present threat of plague and the upheaval of the English Civil War, to the real dangers of childbirth and childhood, we explored just how uncertain life once was.

Drawing on Milton Abbas parish records, Pamela revealed poignant local stories - where survival was never guaranteed, even in our own village.

Join us on **Wednesday 1st April, 7:30pm at the Reading Rooms** for “Discovering the Deserted Medieval Village of Elston.” All are welcome - if you'd prefer to join via Zoom, please contact simonmartin@btinternet.com for details. Refreshments are provided.



Milton Abbas Riding for Disabled Group offer therapeutic horse riding to young disabled children on Tuesdays 5-6.30pm and Fridays 10-12 noon in term time. We are a charity (Reg. no. 1177691) entirely run by volunteers and we raise our own funds to enable us to operate.

If you would like to consider regular volunteering with us, please contact Sue Hodder on 07739 469946 or suehodder01@talktalk.net Thank you so much.

<https://rda.org.uk/>

You can also find us on facebook:-

https://www.facebook.com/p/Milton-Abbas-Riding-for-Disabled-Group-MARDA-100067613680731/?locale=en_GB

Milton Abbas Sports Ground

Hello fellow villagers.

Milton Abbas Sports ground needs your help please! As many of you are aware it has been lovingly restored by a brilliant team of people (you know who you are, and we thank you) We have a brilliant and enthusiastic committee behind the sports ground, and we now want to grow the sports ground and its use.

We have such an abundance of space for fabulous sports to be played and potential opportunities for us as villagers in Milton Abbas to benefit from, but we need to know what you would like to see there.

We can also have events that will enable us to welcome surrounding villages into our fold.

Exciting times ahead!

Please feel free to email your ideas and thoughts to:- miltonabbaspavillion@gmail.com

Many thanks!

M.A.S.C.C.



Milton Abbas Sports Ground (cont.)

We're absolutely thrilled to announce that Milton Abbas Sports Club has been chosen to host a weekly pop up post office in the Pavilion.

The pop up format has been trialled in other local villages and has proved extremely popular but also a great success.

Local businesses might also find this to be convenient.



The poster features the Post Office logo at the top. The main heading is 'Great news' in large blue font. Below this, the text reads: 'We'll be reopening Milton Abbas Post Office as an interim mobile service whilst we continue to seek a solution, at a new location: Milton Abbas Sports Pavilion, Hoggan Down, Milton Abbas, DT11 0BE On Thursday 19 March 2026 at 9:30'. It then provides contact information for a consultation hub: 'If you'd like to know more or to tell us what you think about our plans visit our Consultation Hub - postofficeviews.co.uk We'll be accepting your comments until: Tuesday 17 March 2026'. A QR code is provided for scanning. Below the QR code, it lists 'Other ways to share your views' including email, social media, and phone. To the right, there is an 'Opening hours' table. At the bottom, it provides contact information for Braille, large print, and audio services, and a link to the Post Office website for more information on community engagement.

Opening hours	
Monday	No Service
Tuesday	No Service
Wednesday	No Service
Thursday	09:30 - 13:00
Friday	No Service
Saturday	No Service
Sunday	No Service



Removal of the old village post box underway - captured by **Antony Shearn**

Coffee Stop

Every Tuesday St James Church opens up its south aisle to welcome villagers and passers-by in for a cuppa and a slice of cake.

All are welcome! It is a great way to meet other villagers and catch up on things.

The coffee stop runs from **11am until 12 noon** and we charge just £1 for a drink and another £1 for a slice of cake!

All proceeds go to the up-keep of our beautiful church.



Friday Quilters!



Fridays from 9:30 to 12:00 in the Milton Abbas Reading Room.

You do not have to be a quilter! Bring your knitting or anything else that you are currently working on.

We stop for coffee, tea & biscuits or, if you are lucky, a piece of cake! We will be very pleased to see you.

Further details from **Anthea - 01258 269348**

MA Football

MA Football kicks off on Friday evenings @ 6:30pm. We play on Milton Abbas Sports Field where we can see the sea and play on an excellent small sided pitch to suit 5,6 or 7-a- side games.

Our aim was to gather players of 50+ and get a little bit fitter each week. In truth we have some players in their 40's and had some younger ones too in their 20's as occasional visitors supporting their Dad.



Would you would like to play Football on Fridays? You don't need to be super fit and only need trainers with a grip for the grass pitch.

Contact Martin Kelly: Tel: 07802 260393

WhatsApp or Email: martin@redmailer.co.uk

Computer/Repair Cafe

Got an issue with your computer or mobile phone?

Come along to the Reading Rooms on a Thursday between 10am and 12 noon and we will see if we can help. We ask you to buy a drink and a piece of cake for £2 to cover our costs.

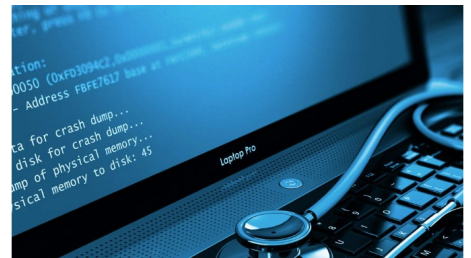

In the spirit of sustainability and community action we're considering joining the growing list of communities running Repair Cafes. We are looking at the idea of a once monthly Repair Cafe to be held alongside Computer Cafe on a Thursday morning - 10.00am to 12.00pm in the Reading Room, Milton Abbas.

As such we're scouting for volunteers who are willing to offer their time and skills to help advise on and repair: small electrical items, tools, clothing and textiles, small wooden items, ceramics, bicycles, etc - saving money and treasured items from going to landfill.

If you think you can help please come and chat to Richard at Computer Cafe or email Sara and Richard at: sara_and_richard@yahoo.co.uk

See <https://www.repaircafe.org/en/about/> for more information on Repair Cafes



Milton Abbas Street Fair – A Potential Crisis

Milton Abbas Street Fair was created in 1973, based on the original St Sampson's Day Fair granted by King Alfred. In the current Fair the village has tried to recreate the flavour of a country occasion using costume, rural crafts and entertainment. The Fair is held every two years at the end of July, close to St Sampson's Day. The Fair generates funds which are used to support local good causes which also benefit the communities in the surrounding villages. In 2015 the Street Fair became a Charitable Trust.

The Fair is set up and run by an Organising Committee. The Committee do the hard work of producing the event.

The Street Fair Charity is administered by a Board of Trustees who among other things consider and dispense the grants to local good causes.

The most recent Fair was held in 2025 and over £16,000 was allocated for grants to local organisations. The next Fair is due to be held in 2027, **but that date and the continued future of the Fair is now at risk.**

Following this year's Fair, key members of the Organising Committee and the Trust have retired. The Organising Committee is short of at least 4 members, including, importantly, a Chair and a Treasurer. The Trustees are also in need of a new Chair and Treasurer.

Work on the 2027 Fair should already be underway, but with the above shortfall in volunteers has been unable to start. Unless new volunteers can be found very soon the next Fair will have to be postponed at least until 2028.

The Street Fair Annual General Meeting is to be held on the 29th April. This is an opportunity to learn more about the Fair. Please save the date and come along.

If you are able to give some time to the Fair either in the Organising Committee or as a Trustee please contact the Trust Secretary, John Widdowson, by email at masftrust@gmail.com. We would be particularly pleased to have new members of the village assisting our teams.

Pews News

Services in March

SUNDAY 1ST MARCH

9am - Turnworth (Communion)
10:30am - Winterborne Stickland (Morning Worship)
10:30am - Winterborne Whitechurch (Communion)

SUNDAY 8TH MARCH

9am - Winterborne Stickland (Prayer Book Communion)
10:30am - Milton Abbas (Communion)
10:30am - Winterborne Cleston (Prayer Book Communion)
4:30pm - Winterborne Houghton (Cafe Church)

SUNDAY 15TH MARCH

9am - Milton Abbas (Prayer Book Communion)
10:30am - Winterborne Stickland (Communion)
11:30am - Winterborne Whitechurch (Cafe Church)

SUNDAY 22ND MARCH

10:30am - Winterborne Houghton (Communion)
4pm - Milton Abbas (SoupSpace)

PALM SUNDAY 29TH MARCH

10:30am - Turnworth (Benefice Service)
2:30pm - Messy Easter



Bible Readings

Sunday 1st March - 2nd Sunday of Lent
Genesis 12. 1 - 4/John 3. 1 - 17

Sunday 8th March - 3rd Sunday of Lent
Exodus 17. 1 - 7/John 4. 5 - 42

Sunday 15th March - Mothering Sunday
Exodus 2. 1 - 10/John 19. 25 - 27

Sunday 22nd March - 5th Sunday of Lent
Ezekiel 37. 1 - 14/John 11. 1 - 45

Sunday 29th March - Palm Sunday
Isaiah 50. 4 - 9/ Matthew 27. 11 - 54

Important Notice

Part of my role as the new Parish Safeguarding Officer is to keep track of safeguarding training and DBS requirements for those holding a position in their parish. Should you receive an email from me seeking permission for me to send you updates on any training you need to complete please could you click the button that agrees to this as promptly as possible.

Your cooperation would be much appreciated.
Debbie

Services in April

HOLY WEEK NIGHT PRAYER 6:30pm - 7pm



Monday 30th March (Turnworth)
Tuesday 31st March (Winterborne Houghton)
Wednesday 1st April (Winterborne Cleston)

MAUNDY THURSDAY 2ND APRIL

7pm - Winterborne Whitechurch
(Screening of The Chosen 'The Last Supper' followed by Communion)

GOOD FRIDAY 3RD APRIL

1pm - Stickland (meet to join our Good Friday walk to Houghton)
2pm - Houghton
(Reflective Service with guided reflections on the Stations of the Cross)

EASTER DAY 5TH APRIL

6am - Winterborne Houghton (Sunrise Service with breakfast)
10:30am - Winterborne Stickland (Morning Worship)
10:30am - Winterborne Whitechurch (Morning Worship)
10:30am - Milton Abbas (Holy Communion)

SUNDAY 12TH APRIL

10:30am - Winterborne Cleston (Prayer Book Communion)
10:30am - Milton Abbas (Communion)

SUNDAY 19TH APRIL

9am - Milton Abbas (Prayer Book Communion)
10:30am - Winterborne Stickland (Communion)
11:30am - Winterborne Whitechurch (Cafe Church)

SUNDAY 24TH APRIL

10:30am - Winterborne Houghton (Cafe Communion)
10:30am - Turnworth (Morning Worship)
4pm - Milton Abbas (SoupSpace)

Upcoming Events

Reading of the Gospel of John

Saturday 7th March 10:30am in the Old School Room Whitechurch

The Chosen Season 5

Dates: Thursdays 26th Feb, 5th, 12th, 19th, 26th March

🕒 Time: 7:30pm-9pm

📍 Location: The Rectory Winterborne Stickland
Please let Lewis know if you'd like to attend

Valley Walk

14th March Lyscombe Nature Reserve. Meet at the church in Houghton at 10am

The Traitors Evening

21st March 7pm. Old school room, Whitechurch

Rector - Rev'd Lewis Pearson
rev@lewispearson@gmail.com - 01258 880482
Chaplain to Milton Abbey School - Tuesday
Day Off- Friday

Admin & Pews News - Jennifer Harrison
wrmabenefice@gmail.com

www.wrmabenefice.co.uk

March Picture Quiz Result:



Well this one was clearly far too easy. Barely had I hit “Send” before the first correct answer came in!

This is (obviously, as it turns out!) one of the pillars outside the front door of the reading rooms in the centre of the Almshouses

Well done to Baz Towers for the first correct response!

April Picture Quiz:

Do you know where this was taken?

Recognise the image?

Drop us an email and let us know!

The first correct responder gets their name in next month's MA Bulletin.



Articles and Feedback Gratefully Received:

MiltonAbbasBulletin@GMail.com

or contact:

Paula Driver

Stuart Driver